



Please cite this paper as follows:

Gholami, M. J., Pishghadam, R., & Shayesteh, S. (2021). Emosensory competence, as an undisclosed construct of communicative competence, predicts L2 speaking ability. *Journal of Research in Applied Linguistics*, 12(1), 33-47. <https://doi.org/10.22055/RALS.2021.16723>

Research Paper

Emosensory Competence, as an Undisclosed Construct of Communicative Competence, Predicts L2 Speaking Ability

Mohammad Javad Gholami¹, Reza Pishghadam², & Shaghayegh Shayesteh³

¹Department of English and Literature, Faculty of Letters and Humanities, Ferdowsi University of Mashhad, Mashhad, Iran; mjgholamihosseinabad@stu.um.ac.ir

²Corresponding author, Department of English and Literature, Faculty of Letters and Humanities, Ferdowsi University of Mashhad, Mashhad, Iran; pishghadam@um.ac.ir

³Department of English and Literature, Faculty of Letters and Humanities, Ferdowsi University of Mashhad, Mashhad, Iran; shayesteh@um.ac.ir

Received: 11/09/2020

Accepted: 28/01/2021

Abstract

Given the undeniable significance of communication in language education, different models have been proposed to render communicative competence (CC) and its constructs. However, there seems to be an undisclosed construct which considers individuals' real-world knowledge and sensory experiences essential in initiating and maintaining communication. To have an update on the existing models, this study introduces the emosensory account to the underlying competence of CC. Specifically, the study pursued to, first, develop and substantiate the emosensory competence (ESC) questionnaire and, then, to investigate the extent to which ESC predicts L2 speaking ability. To this end, 254 EFL learners filled out the ESC questionnaire in phase 1. In phase 2, the degree of ESC of 184 participants was analyzed in relation to their IELTS speaking scores. Results revealed that the ESC questionnaire enjoys psychometric properties and that, unlike socioemotional and sensory domains, cognitive topics are negative predictors of L2 speaking ability.

Keywords: Communicative Competence; Emosensory Competence; Emotionency; Speaking Ability; Willingness to Communicate

1. Introduction

It is widely accepted that communication is the main aim of language teaching and learning. In accordance, communicative competence (CC), which accentuates the indispensable role of communication (Canale & Swain, 1980, 1983; Hymes, 1972), turns out to be as one of the most distinguished theories in language studies (Bachman, 1990; Richards & Schmidt, 2010). The term CC, in general, is concerned with some competencies that enable individuals to communicate effectively and appropriately in different settings. In the early 1970s, as a pioneer, Hymes (1972) claimed that CC comes under four interwoven parts namely grammatical, sociocultural, psycholinguistic, and de facto. Later, Canale and Swain (1980) captured CC using a model with grammar, sociolinguistic, and strategic competences. Following this trend, throughout almost five decades, different models have been discussed and further developed to characterize the theoretical underpinning of CC relying on four typical areas of knowledge. As defined by Richards and Schmidt (2010), grammatical competence (also referred to as formal competence) involves grammar, vocabulary, and so on; sociolinguistic competence (also called sociocultural competence) is the knowledge of connections between language and nonlinguistic, social contexts; discourse competence is about the knowledge of beginning and closing a conversation; and strategic competence focuses on using some strategies to compensate for weaknesses in other areas of language.

In addition to the aforementioned competencies underlying CC which have been broadly investigated in the L2 literature as predictors of learners' willingness to communicate (WTC), we hypothesize that there are other undisclosed competencies including the one related to real-world knowledge and the diversity of sensory experiences which may conceivably affect learners' communication in various ways (Pishghadam, 2016a, 2016b; Pishghadam, Jajarmi, &



Shayesteh, 2015). According to Pishghadam, Adamson, and Shayesteh (2013), these sensory experiences give rise to unique emotions, coined as *sensory emotions*, which may eventually modify the degree and quality of communication. Being able to identify and address the previous emosensory experiences (i.e., the experiences related to sensory emotions) of individuals during interactions triggers their WTC and helps maintain communication. To evidence, different experimental studies have thus far examined the role of emosensory experiences in communication and WTC. As for one, Makiabadi, Pishghadam, Naji Meidani, and Khajavy (2019) maintained that emosensory experiences influence L2 learners' willingness to write, listen, read, and speak in an L2. In another study, Borsipour, Pishghadam, and Naji Meidani (2019) confirmed the role of sensory emotions toward different topics in the EFL learners' willingness to read.

Taken together, we believe that, emosensory competence (ESC), as the ability to pay increased attention to the emosensory domain of interlocutors during communication, has potential merits for CC, which, to our best knowledge, has not received adequate attention. Therefore, the current study seeks to develop and substantiate the ESC questionnaire to measure L2 learners' awareness of the concept and further explore if it has any relationship with the Iranian EFL learners' speaking ability, as a subconstruct of WTC. In the following, we will concisely review a number of models and constructs related to CC and rather elaborate on Pishghadam, Tabatabaeyan, and Navari's emotioncy model (2013) as the underlying cornerstone of the proposed questionnaire.

2. Literature Review

2.1. Communicative Competence

The origin of CC dates back to 1972 when Hymes presented the notion of CC as a reaction to the theory of language competence proposed by Chomsky (1965). Chomsky made a distinction between competence (one's knowledge of a language) and performance (the actual use of language in actual situations) which was mostly based on a classical view of linguistics. Hymes (1972) expressed his strong disagreement with Chomsky's idea that communicating in a language is not only the mastery of grammatical competence of a language to produce grammatically correct utterances, but also knowing how to deploy that competence to communicate in a variety of contexts and situations appropriately. In Hymes' model (1972), in addition to linguistic competence, there are three more competencies: sociocultural (contextual appropriateness), psycholinguistic (i.e., implementational feasibility), and de facto (i.e., actual occurrence).

Moreover, Canale and Swain (1980) defined CC as "a combination of linguistic knowledge, which is one's knowledge of language that can be either conscious or unconscious, and skills required for communication" (p. 23). Along with Hymes (1972), Canale and Swain (1980) pointed out that grammatical rules would be pointless without rules and conventions of language use. Furthermore, they pointed out that no scholars took the techniques and strategies (e.g., paraphrasing) that are used to compensate for communication break-downs (e.g., false starts) into considerations. Canale and Swain (1980) proposed a model with three competencies: grammar competence, sociolinguistic competence, and strategic competence. In 1983, Canale revised the previous model and proposed a newer version of that by taking some elements out of sociolinguistic competence and adding discourse competence to the previous competencies.

Similarly, Bachman (1990) and Bachman and Palmer (1996) proposed communicative language ability (CLA) and defined it as "both knowledge, or competence, and the capacity for implementing, or executing that competence in appropriate, contextualized communicative language use" (Bachman, 1990, p. 84). Following Hymes' model, Bachman (1990) and Bachman and Palmer (1996) also proposed another model of CC or theoretical framework of language ability, which was a more comprehensive model than the previous ones with three main components: language competence, strategic competence, and psychophysiological mechanisms (see Figures 1 and 2):

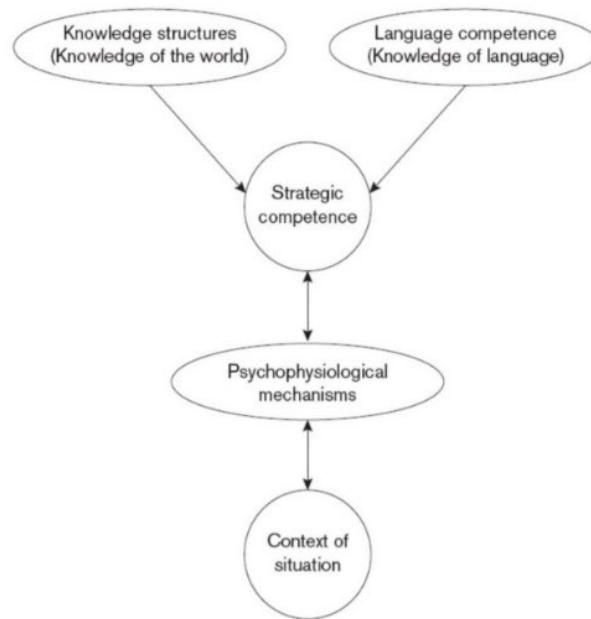

Figure 1. Components of Communicative Language Ability. Adapted from *Fundamental Considerations in Language Testing* (p. 85) by L. F. Bachman, 1990, Oxford University Press, Copyright 1990 by Lyle F. Bachman

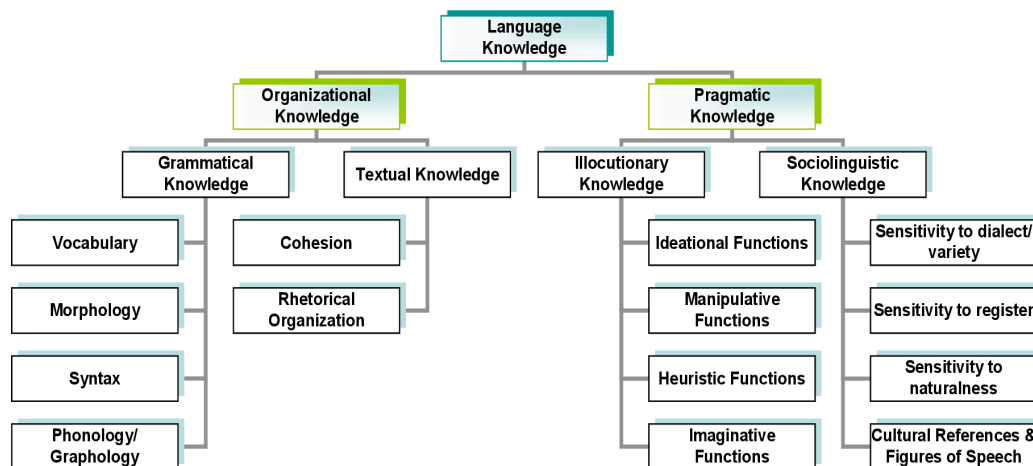

Figure 2. Bachman's (1990) and Bachman and Palmer's (1996) model of language competence. Adapted from *What's in a Grade? A Mixed-Methods Investigation of Teacher Assessment of Grammatical Ability in L2 Academic Writing* by H. Neumann, 2010, McGill University, Montreal

Also, Celce-Murica, Dörnyei, and Thurrell (1995) presented another model of CC with five competencies of linguistic competence, sociocultural competence, strategic competence, discourse competence, and actional competence. The main aim of this model was to enlarge upon sociolinguistic competence, which was a separate part from discourse competence. Moreover, the Common European Framework (CEF; 2001) proposed another model used for assessment, learning, and teaching of languages. In this model, CC is summarized only in knowledge with three components—language competence, sociolinguistic competence, and pragmatic competence—and each component refers to the knowledge of contents and the capability to employ it (Bagaric & Djigunovic, 2007). More recently, Littlewood (2011) proposed another model with five competencies: linguistic competence, discourse competence, pragmatic competence, sociolinguistic competence, and sociocultural competence.

Having defined CC and proposed various models for it, a great number of researchers (e.g., Hadiani, 2019; Ibrahim, 2018; Khalili & Beheshti, 2016) have investigated the role of CC in language skills, but it is obvious that

speaking gains more importance than other language skills when considering communication (Fan, 2010; Febriyanti, 2011; Susanto, 2012). It must be taken into account that individuals with all their specific differences should be able to communicate efficiently and the main aim of teaching an L2 must be to prepare L2 learners who can express a considerable interest to communicate with others (Riasati & Noordin, 2011).

2.2. Willingness to Communicate

MacIntyre, Clément, Dörnyei, and Noels (1998) defined WTC as “a readiness to enter into discourse at a particular time with a specific person, or persons, using an L2” (p. 547). McCroskey and Richmond (1990), first, developed the notion of WTC as a character-like propensity among individual differences in L1 and soon after them, MacIntyre and Charos (1996) introduced WTC to L2 literature. They considered some factors affecting WTC, namely, communication apprehension or communicative anxiety (the fear or anxiety related to either actual or anticipated communication with others; McCroskey, 1997), self-perceived communicative competence (SPCC; the feeling that an individual has the competence or ability to communicate effectively at a particular moment; MacIntyre et al., 1998), motivation, personality, content, context, gender, and age.

Along with McCroskey and Richmond (1996), MacIntyre et al. (1998) developed the concept of WTC and pointed out that WTC includes two kinds of properties: trait (stable) and state (transient) properties. They explained that some of the properties are more stable, whereas some others vary from time to time. The WTC model, proposed by MacIntyre et al. (1998), includes all psychological, social, linguistic, and affective variables and factors in six layers to describe, elaborate on, and predict communication in L2 (see Figure 3):

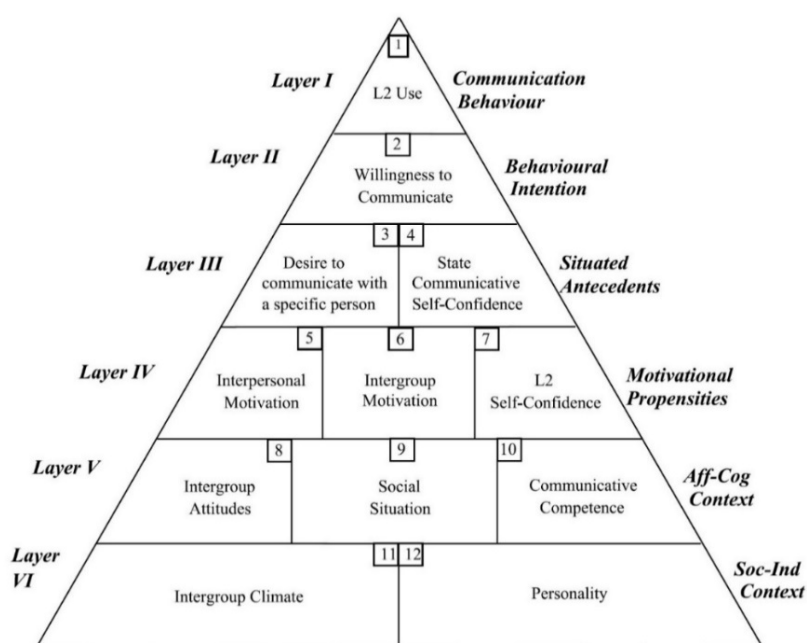

Figure 3. Willingness to Communicate Model. Adapted from “Antecedents of Willingness to Communicate: A Review of Literature” by M. J. Riasati and N. Noordin, 2011, *Studies in Literature and Language*, 3(2), p. 77.

Copyright 2011 by the Canadian Research & Development Center of Sciences and Cultures

According to MacIntyre et al. (1998), Communication Behavior (Layer I) is concerned with L2 use which is “the result of a complex system of interrelated variables” (p. 547). Behavioral Intention (Layer II) concerns with willingness to communicate. Situated Antecedents of Communication (Layer III) consists of two variables: the desire to establish communication with a specific person and state communicative self-confidence. Motivational Propensities (Layer IV) includes three elements: (a) interpersonal motivation, (b) intergroup motivation, and (c) L2 confidence. Affective-cognitive Context (Layer V) consists of intergroup attitudes, social situations, and CC. As the last layer, Societal and Individual Context (Layer VI) includes two variables: (a) intergroup climate and (b) personality.

2.3. Emotioncy Model

Following Greenspan's DIR model (1992), Pishghadam, Tabatabaeyan et al. (2013) introduced the new concept of *emotioncy* and proposed the emotioncy model to describe that emotions provoked by sensory input can shape cognition. As Table 1 shows, emotioncy (which is a blend of emotion + frequency) has several types including null, auditory, visual, kinesthetic, inner, and arch emotioncies which are categorized into three kinds: avolvement (null), exvolvement (auditory, visual, and kinesthetic), and involvement (inner and arch):

Table 1. *Emotioncy Types*

Type	Experience
Null Emotioncy	When an individual has not heard about, seen, or experienced an object or a concept.
Auditory Emotioncy	When an individual has merely heard about a word/concept.
Visual Emotioncy	When an individual has both heard about and seen the item.
Kinesthetic Emotioncy	When an individual has touched, worked, or played with the real object.
Inner Emotioncy	When an individual has directly experienced the word/concept.
Arch Emotioncy	When an individual has done research to get additional information.

Note. Adopted from "Conceptualizing Sensory Relativism in Light of Emotioncy: A Movement beyond Linguistic Relativism" by R. Pishghadam, H. Jajarmi, S. Shayesteh. 2016, *International Journal of Society, Culture & Language*, 4(2), 14. Copyright 2015 by IISCL

According to emotioncy model (Figure 4), for example, if an individual has no experience of meat, his emotioncy is null (or zero) and is in the avolvement level. If he has heard about meat, his emotioncy is auditory and he is in the exvolvement level. As the next level of emotioncy, if he has heard about and seen meat, his emotioncy level is visual and he is still in exvolvement level. Kinesthetic emotioncy means that he has heard about, seen, and touched meat. Similar to auditory and visual emotioncies, kinesthetic emotioncy is also considered as a part of the exvolvement level. As the last level of the emotioncy model, involvement means that if a person has heard about, seen, touched, and eaten meat, his emotioncy is inner, and if, besides his previous experiences with meat, he has done research to get some more information about it, his emotioncy is arch emotioncy:

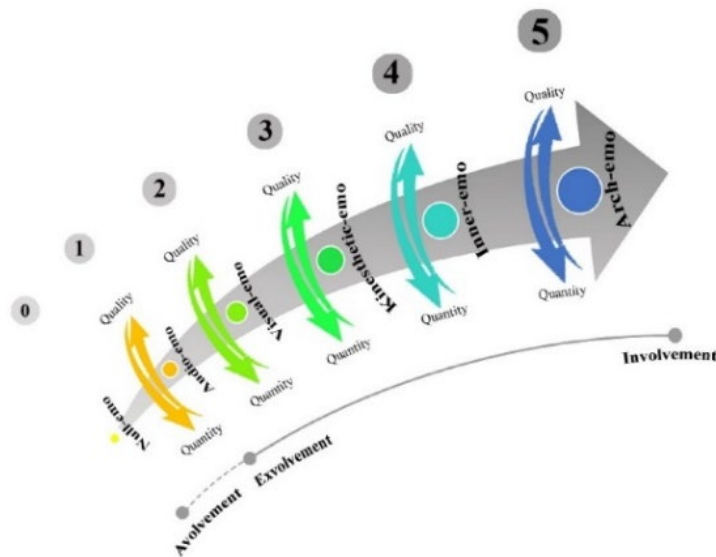

Figure 4. Emotioncy Levels. Adapted From "Emotioncy in Language Education: From Exvolvement to Involvement" by R. Pishghadam, 2015, October, Paper presented at the 2nd Conference of Interdisciplinary Approaches to Language Teaching, Literature, and Translation Studies, Iran, Mashhad

Considering the emotioncy model as the core element, a great number of studies (e.g., Makiabadi et al., 2019; Pishghadam, 2015, 2016a, 2016b; Pishghadam & Abbasnejad, 2016, 2017; Pishghadam & Shayesteh, 2016, 2017a, 2017b; Pishghadam, Seyednozadi, & Zabetipour, 2017) have been carried out to shed more light on the effect of senses and the emotions generated by them on language-related issues and communication. Pishghadam and Shayesteh (2016) explored the effect of the emotioncy on learning vocabulary of participants with different social status and found that as the social status of individuals vary from low to high, the degree of vocabulary learning increases accordingly. Moreover,

Pishghadam (2016a) explored the relationship between emotioncy, anxiety, and extraversion, and WTC in English and found that emotioncy is positively correlated to WTC in a way that involved learners had higher WTC than their exvolved counterparts. Similarly, Makiabadi et al. (2019) explored the relationships between three sensory emotioncy types, namely emotional, cognitive, and sociocultural, and WTC. Their results indicated that all of these sensory emotioncy types were positively correlated with the subscales of WTC in L2. Also, they found that cognitive type is a great positive predictor of willingness to read and willingness to listen.

Overall, it is assumed that the emotioncy model as the core of CC has the potential to contribute to communication. To verify this hypothesis, the current study intends to develop a questionnaire to specifically measure ESC, study the relationship between ESC and speaking proficiency level, and discuss considering ESC as a further constituent of CC.

3. Methodology

3.1. Participants

The study consisted of two different phases: For the first phase, 254 male and female participants, with the age range of 16 to 52 years old ($M = 29.18$, $SD = 5.85$), were chosen. Their L1 was Persian and they were at different levels of English proficiency (from elementary to advanced levels). The participants' academic background varied from high school degree to Ph.D. (high school, $N = 5$; diploma, $N = 15$; B.A./B.S., $N = 97$; M.A./M.S., $N = 121$; Ph.D., $N = 16$) and were all students of IELTSDaily Language Academy, located in Mashhad, Iran.

For the second phase of the study, 184 participants were selected. They all had a written report of the IELTS mock test (held at IELTSDaily Language Academy), a recorded interview, and a speaking score based on the IELTS speaking guidelines.

3.2. Instruments

3.2.1. Emosensory Competence (ESC) Questionnaire

To evaluate the participants' ESC, the ESC questionnaire was developed. It included 18 items with six options for each. The options were in the form of questions, each representing one level of the emotioncy model (i.e., null, auditory, visual, kinesthetic, inner, and arch; see Appendix for sample questions).

3.2.2. Participants' IELTS Mock Test Written Reports

To check the relationship between the speaking ability of the participants and their ESC, the participants' mock test written reports were needed to obtain their speaking score. These written reports were taken from IELTSDaily Mock Test Department and were sorted out based on the participants' IELTS speaking score ranging from 3 to 8.5.

3.3. Procedure

3.3.1. Questionnaire Development

To come up with the 18 items, different models were put to use. According to the structure of the brain and drawing upon Makiabadi et al.'s (2019) scale with three domains of sociocultural, emotional, and cognitive, the ESC questionnaire was developed by merging the sociocultural and emotional domains into the socioemotional domain and adding sensory domain representing the five senses. The emotioncy model (Pishghadam, Tabatabaeyan et al., 2013) was also used to generate the six options. The 18 items were, further, categorized into three different groups (i.e., equal, high-low, and low-high) based on Scollon and Scollon's model (1995) in terms of the relationship status between the participants involved in the interaction. Therefore, there were six items for the equal level (e.g., a friend to a friend), six items for the high-low level (e.g., a parent to a child), and six items for the low-high level (e.g., an employee to a boss). To reduce the possibility of confusion caused by the participants' different English language proficiency levels, the questionnaire was developed in Persian. It was, then, piloted to five individuals to maintain clarity. Table 2 shows the overall description of the items of the ESC questionnaire:

Table 2. Overall Description of Items of ESC Questionnaire

Item	Domain	Context	Relationship Status	Relationship
01	Cognitive	Learning a New Language	Equal	Friend-Friend
02	Socioemotional	Participation in Elections	Low-High	Employee-Boss
03	Sensory	Watching a Series	High-Low	Uncle/Aunt- Nephew/Niece
04	Cognitive	Doing Research	High-Low	Manager-Employee
05	Socioemotional	Participation in Religious Ceremonies	High-Low	Uncle/Aunt- nephew/Niece
06	Sensory	Visiting Historic Monuments	Low-High	Child-Parent
07	Cognitive	Playing Games	High-Low	Parent-Child
08	Socioemotional	Participation in Festivals and Celebrations	Equal	Colleague- Colleague
09	Sensory	Listening to Music	Equal	Spouse-Spouse
10	Cognitive	Computer Programing	Equal	Brother/Sister- brother/Sister
11	Socioemotional	Gardening	High-Low	Resident-Janitor
12	Sensory	Perfume	Equal	Classmate- Classmate
13	Cognitive	Translating	Low-High	Employee-Manager
14	Socioemotional	Giving/Receiving Gifts	Low-High	Nephew/Niece- Uncle/Aunt
15	Sensory	Fruits and Foods	Low-High	Child-Parent
16	Cognitive	Poetry Contest	Low-High	Child-Parent
17	Socioemotional	Playing a Musical Instrument	Equal	Friend-Friend
18	Sensory	Touching a Cloth	High-Low	Parent-Child

3.3.2. Data Collection

Having obtained permission from the CEO of the academy, the students' phone numbers were taken and they, then, were asked to fill out the Web-based ESC questionnaire. Thereafter, the participants' mock test written reports as well as their speaking scores were collected

3.3.3. Data Analysis

To analyze the data, SPSS (version 25) and Amos (version 26) were utilized. In the first place, the normality of the data was checked. Afterward, to investigate the first research question concerning the construct validity of the ESC questionnaire, confirmatory factor analysis (CFA) was used. To investigate the second research question (i.e., the relationship between ESC and speaking ability), structural equation modeling (SEM) was utilized.

4. Results

4.1. Descriptive Statistics

Descriptive statistics, including mean and standard deviation, for the ESC questionnaire and its underlying subconstructs (i.e., cognitive, socioemotional, and sensory) can be seen in Table 3:

Table 3. Descriptive Statistics for ESC Questionnaire and Its Subconstructs

	Min	Max	Mean	SD
ESC	1.83	13.33	8.65	1.90
Cognitive	0.00	5.00	2.94	.99
Socioemotional	0.00	4.75	2.72	.88
Sensory	0.00	4.80	2.97	.86

As the first step, the normality of the data was verified. According to Table 4, the Skewness and Kurtosis estimates are within the range of -2 and +2, which indicate the normality of the distribution:

Table 4. Normality Test for ESC Questionnaire

Variable	Skewness	Kurtosis
ESC	.22	-.33

4.2. Validation of ESC Questionnaire

The ESC questionnaire was substantiated from two different perspectives, namely the emotioncy model (2015) and Scollon and Scollon’s (1995) view of communication. To substantiate the construct validity of the ESC questionnaire from the emotioncy model perspective, CFA was used. Prior to CFA, Harman’s single factor test was conducted. The result indicated that the first factor accounted for only 8.16% of the variance, confirming the construct’s multidimensionality. The questionnaire includes three subconstructs of cognitive, socioemotional, and sensory. Standardized factor loadings can be seen in Figure 5. Each subconstruct had six items; yet, some items were removed from the questionnaire to improve model fit. Goodness-of-fit indices are reported in Table 5:

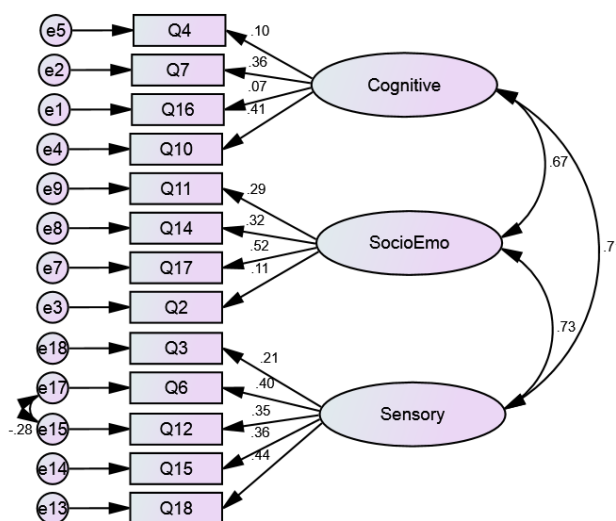

Figure 5. Measurement Model for ESC From Emotioncy Model Perspective

As Figure 5 shows, 15 items out of 18 were validated and five items were removed from the ESC questionnaire. The sensory domain turned out to have the highest number of items, with 5 items remaining after validation and 1 item # 9 was removed. In the socioemotional domain, 4 items out of 6 were validated and only 2 items (i.e., items # 5 and 8) were removed from the questionnaire. In a similar vein, 4 items out of 6 items of the cognitive domain were validated and items # 1 and 13 were removed.

To substantiate the construct validity of the ESC questionnaire from the Scollon and Scollon’s (1995) view of communication, CFA was used. ESC includes three subconstructs of high-low, equal, and low-high. Standardized factor loadings can be seen in Figure 6. Each subconstruct had six items; yet, some items were removed from the questionnaire to improve model fit. Goodness-of-fit indices are reported in Table 5:

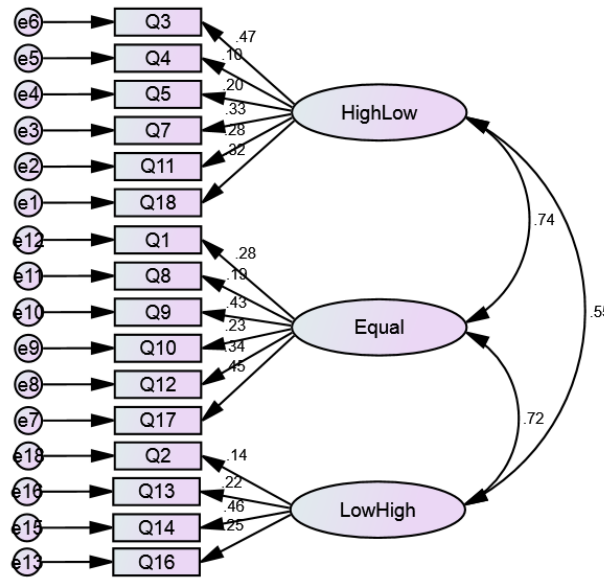

Figure 6. Measurement Model for ESC From the Scollon and Scollon’s (1995) View of Communication

As Figure 6 illustrates, the three different categories of the relationships between the participants (i.e., high-low, equal, and low-high) were validated. The high-low group comprised 6 items (i.e., items # 3, 4, 5, 7, 11, 18), all of which were validated. Similarly, all the items in the equal group (i.e., items # 1, 8, 9, 10, 12, and 17) were validated. Among the items in the low-high group (i.e., items # 2, 6, 13, 14, 15, and 16), only items # 2, 13, 14, and 16 were validated and items # 6 and 15 were removed.

To see whether the models fit the data, goodness of fit indices were calculated using Amos. Table 5 illustrates the relative chi-square which equals the chi-square index divided by the degrees of freedom (χ^2/df), Comparative Fit Index (CFI), Tucker-Lewis Index (TLI), Root Mean Square Error of Approximation (RMSEA), and Standardized Root Mean Squared Error (SRMR). The criterion for acceptance is different across researchers; in the present study, χ^2/df should be less than 3 (Ullman, 2001), TLI and CFI should be over .90, and RMSEA and SRMR should be less than .08 (Browne & Cudeck, 1993). Based on the obtained results (see Table 5), the models fit the data adequately; hence, confirming the structure of the ESC questionnaire from both perspectives:

Table 5. Goodness-of-Fit Indices for CFA Models

Models	χ^2/df	df	CFI	TLI	RMSEA	SRMR
ESC (Emotioncy Model)	1.03	61	.97	.96	.01	.05
ESC (Scollon & Scollon)	.98	101	1.00	1.00	.00	.05

4.3. Reliability of ESC Questionnaire

The overall reliability of the ESC questionnaire was $\alpha = .76$, which is considered acceptable.

4.4. Correlational Analyses

As Table 6 reveals, some variables are significantly correlated with each other. Whereas there exist significant relationships between the subconstructs of ESC, the speaking score is merely correlated with the cognitive variable ($r = -.20$):

Table 6. Correlational Analysis of Variables

	1	2	3	4	5
Cognitive	1				
Socioemotional	.24**	1			
Sensory	.21**	.71**	1		
Overall ESC	.70**	.00	-.05	1	
Speaking Score	-.20**			-.12	1

**Correlation is significant at the 0.01 level (2-tailed).



4.5. SEM

To check the predictive power of the independent variables, SEM was conducted. A model was proposed for the prediction of the speaking scores (i.e., speaking ability). As Figure 7 illustrates, the cognitive variable is a negative predictor of speaking scores ($\beta = -.21, p < 0.001$). That is, for cognitive topics, the participants followed the emotioncy model and asked their questions in such a way to emotionalize the concepts in the listeners. To justify the negative relationship, it should be mentioned that, the participants who tended to start their conversation using avolved (null = 0) or exvolved (auditory = 1, visual = 2, and kinesthetic = 3) questions (moving in the opposite direction of the emotioncy model) had a higher speaking score:

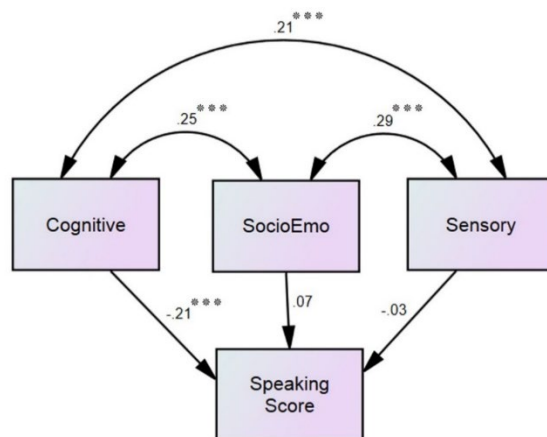

Figure 7. Schematic Representation of Relationships Among Cognitive, Socioemotional, Sensory, and Speaking Score

5. Discussion

The first aim of the present study was to develop a questionnaire to measure individuals' ESC. To do so, the data were collected and analyzed based on the three domains of cognitive, socioemotional, and sensory. After validating the questionnaire, 15 items out of 18 were validated and 3 items were removed from the questionnaire. Among the three domains, the sensory domain turned out to have the highest number of items with 5 items remained after validation, and only item # 9, representing the context of listening to music, was removed. It seems that this item was probably removed due to the popularity of the artists, mentioned in the item. The rest of the items were well-functioning enough to measure this domain of ESC.

In the socioemotional domain, items # 5 and 8 were removed and 4 items remained. Because item # 5 included Ashura, the participants were mostly in the inner emotioncy level with roughly similar emosensory experiences. Therefore, their answers did not vary enough to validate the item. This could be in line with the findings of Pishghadam (2016a), indicating that the high familiarity of a topic to individuals could put them in inner and arch emotioncy levels. In addition, item # 8 exemplified La Tomatina, a Spanish festival. Because the familiarity of the participants with this festival is relatively low, the majority of them chiefly preferred to start their conversation with the option representing the null emotioncy level. Considering items # 5 and 8 that were removed because of high and low familiarity of the participants with the examples, it is possible that if the examples for these contexts had been substituted with more suitable ones for which the individuals had widely different emosensory experiences, they could have been validated, as well.

In addition to the sensory and socioemotional domains, in the cognitive domain, items # 1 and 13 were removed and 4 items out of 6 were validated. The possible reason behind the elimination of item # 1 can be the Hindi language. Because Hindi is not a very common language to be learned and spoken in Iran, the participants' answers did not have enough variance to validate the item. Similarly, item # 13, representing the context of translating a foreign language with the example of Spanish, was removed from this domain because Spanish, compared to English, French, or German, is not a favorite language to be learned by Iranians. Therefore, the participants had little emosensory experiences about it. It can be deduced that items # 1 and 13 were probably removed from the questionnaire due to lack of or low familiarity of the participants with Spanish and Hindi, and that changing the languages with more common ones might lead to the validation of these items.

The ESC questionnaire was developed based on the three relationship status levels (i.e., low-high, high-low, and equal), taken from Scollon and Scollon's study (1995) and each level comprised six items. As mentioned before, all the three different categories of the relationships between the participants were validated. All of the items related to the high-low level (i.e., items # 3, 4, 5, 7, 11, and 18) and the equal level (i.e., items # 1, 8, 9, 10, 12, and 18) were validated. It shows that the contexts and the relationship status in the contexts were well-matched. Four of the items of the high-low level were also validated, and two (items # 6 and 15) were removed. Because both items were about a child-parent relationship, a possible explanation for the elimination of these two items can be that the participants did not usually talk about these topics with their parents. Another probable justification could be that the options were not probably suitable to fit the relationship between a child and a parent. In other words, perhaps children and parents do not normally begin their conversations about these topics with such questions in real-life situations.

In order to address the second question of the study, SEM was used. The overall results indicated that the cognitive domain is a negative predictor of one's speaking score. In other words, regarding cognitive topics, the participants who tended to begin their conversations with the options representing avolved (null) and exvolved (auditory, visual, and kinesthetic) emotioncies had higher speaking scores. It shows that the higher the participants' speaking score is, the more they probably tend to start their conversations with basic and general information, representing lower levels of emotioncy. As L2 learners' speaking ability improves, they would probably gain awareness that in order to maintain communication and decrease the cognitive load (Ginns & Leppink, 2019; Sweller, 1988) on the person on the other side that might lack enough emosensory experiences about the topic, they need to begin their conversations with more fundamental and general information. Another possible reason for this finding could be that the participants attach more importance to the cognitive topics, compared to the topics in the sensory and socioemotional domains because they consider cognitive topics more serious to discuss. Therefore, when initiating a conversation about a cognitive topic, they tend to ensure that the person on the other side is, at least, in the avolved level by starting from basic information, and afterward, by moving forward to the exvolved and involved emotioncies, they will be able to establish good communication and avoid having possible breakdowns. This finding contradicts those of Makiabadi et al. (2019) arguing that the cognitive domain has a positive impact on individuals' WTC and ultimately their speaking score.

Also, the results revealed that socioemotional and sensory topics do not predict one's speaking ability. This finding is in contrast with those of Thornton, Jones, and Toohey (1982) arguing that senses and sensory experiences can highly affect and predict language learning and ultimately speaking ability. Moreover, the findings of the present study are in contrast to those of Makiabadi et al. (2019) claiming that the sociocultural and emotional domains can predict one's speaking ability and WTC.

6. Conclusion

The present study intended to develop a questionnaire, measuring individuals' ESC and examine the relationship between ESC and speaking ability. The results showed that the ESC questionnaire enjoys psychometric properties. It was also revealed that whereas socioemotional and sensory topics do not predict one's L2 speaking ability, cognitive topics are negative predictors of this ability.

The outcomes of this study can be of practical use for different groups of individuals. In the first place, this scale can be used to attract L2 teachers' attention to their learners' ESC. L2 learners are expected to get familiar with the ways to check the level of emotioncy in different topics. Second, considering different variables affecting the speaking ability, it seems that the ESC can be a new variable to be explored more deeply by teacher trainers and researchers.

This study can be improved if the following issues are taken into consideration: First, because the focus of the study was on speaking, another study can be done to examine the role of ESC in other skills. Additionally, we used IELTS band scores for speaking as a measure of the participants' L2 speaking ability. It is highly suggested that the study be replicated using the speaking module of other tests such as TOEFL to determine the participants' speaking ability. It can also be great to include the variables of gender, age, educational background, and learning styles of the participants in further studies.

References

- Alwaqassi, S. A. (2017). *The use of multisensory in schools today*. Unpublished master's thesis, Indiana University, Indiana, USA.
- Bachman, L. F. (1990). *Fundamental considerations in language testing*. Oxford University Press.
- Bachman, L. F., & Palmer, A. S. (1996). *Language testing in practice: Designing and developing useful language tests*. Oxford University Press.
- Bagaric, V., & Djigunovic, J. M. (2007). Defining communicative competence. *Metodika*, 8(1), 94-103.
- Birsh, J. R., & Carreker, S. (2018). *Multisensory teaching of basic language skills*. Baltimore, Maryland: Paul H. Brookes Publishing Co.
- Borghi, A. M., & Cimatti, F. (2010). Embodied cognition and beyond: Acting and sensing the body. *Neuropsychologia*, 48(3), 763-773.
- Borsipour, B., Pishghadam, R., & Naji Meidani, E. (2019). The role of sensory emotions in increasing willingness to read in EFL learners. *Publicaciones: Facultad de Educación y Humanidades del Campus de Melilla*, 49(2), 169-189.
- Caballero, R., & Paradis, C. (2015). Making sense of sensory perceptions across languages and cultures. *Functions of Language*, 22(1), 1-19. <https://doi.org/10.1075/foL.22.1.01cab>
- Canale, M. (1983). From communicative competence to communicative language pedagogy. In J. C. Richards & R. W. Schmidt (Eds.), *Language and communication* (pp. 2-27). London: Longman.
- Canale, M., & Swain, M. (1980). Theoretical bases of communicative approaches to second language teaching and testing. *Applied Linguistics*, 1(1), 1-47.
- Celce-Murcia, M., Dörnyei, Z., & Thurrell, S. (1995). Communicative competence: A pedagogically motivated model with content specifications. *Issues in Applied Linguistics*, 6(2), 5-35.
- Chomsky, N. (1965). *Aspects of the theory of syntax*. Cambridge, Massachusetts: The M.I.T. Press.
- Council of Europe (2001). *Common European framework of reference for languages: Learning, teaching, and assessment*. Cambridge University Press.
- Derakhshan, A., Khalili, A. N., & Beheshti, F. (2016). Developing EFL learners' speaking ability, accuracy, fluency. *English Language and Literature Studies*, 6(2), 177-186.
- Dev, P. C., Doyle, B. A., & Valente, B. (2002). Labels needn't stick: "At-risk" first graders rescued with appropriate intervention. *Journal of Education for Students Placed at Risk*, 7(3), 327-332.
- Dewey, J. (1906). *Studies in logical theory*. The University of Chicago Press.
- Fan, F. (2010). A discussion on developing students' communicative competence in college English teaching in China. *Journal of Language Teaching and Research*, 1, 111-116.
- Febriyanti, E. R. (2011). Teaching speaking of English as a foreign language: Problems and solutions. *Journal Bahasa, Sastra, dan Pembelajaran*, 1(2), 133-146.
- Gadt-Johnson, C., & Price, G. (2000). Comparing students with high and low preferences for tactile learning. *Education*, 120(3), 581-585.
- Ginns, P., & Leppink, J. (2019). Special issue on cognitive load theory: Editorial. *Educational Psychology Review*, 31, 255-259.
- Greenspan, S. I. (1992). *Infancy and early childhood: The practice of clinical assessment and intervention with emotional and developmental challenges*. Madison, Connecticut: International Universities Press.
- Hadiani, D. (2019). An analysis of students' writing skills: Focus on grammatical and discourse competence. *LLT Journal: A Journal on Language and Language Teaching*, 22(2), 198-208.

- Hymes, D. H. (1972). On communicative competence. In J. B. Pride & J. Holmes (Eds.), *Sociolinguistics* (pp. 269-293). Baltimore, USA: Penguin Education, Penguin Books Ltd.
- Ibrahim, N. A. (2018). Developing communicative performance through effective reading on second language learners. *American Journal of education and Information Technology*, 2(1), 1-4.
- Jubran, S. (2012). Using multisensory approach for teaching English skills and its effects on students' achievement at Jordanian schools. *European Scientific Journal*, 8(22), 50-61
- Leppink, J. (2017). Cognitive load theory: Practical implications and an important challenge. *Journal of Taibah University Medical Sciences*, 12(5), 385-391.
- Littlewood, W. (2011). Communicative language teaching: An expanding concept for a changing world. In E. Hinkel (Ed.), *Handbook of research in second language teaching and learning* (pp. 541-557). London, UK: Routledge.
- Macintyre, P. D. (2007). Willingness to communicate in the second language: Understanding the decision to speak as a volitional process. *The Modern Language Journal*, 91(4), 564-576. <https://doi.org/10.1111/j.1540-4781.2007.00623.x>
- MacIntyre, P. D., & Charos, C. (1996). Personality, attitudes, and affect as predictors of second language communication. *Journal of Language and Social Psychology*, 15(1), 3-26.
- Macintyre, P. D., Clément, R., Dörnyei, Z., & Noels, K. A. (1998). Conceptualizing willingness to communicate in an L2: A situational model of L2 confidence and affiliation. *The Modern Language Journal*, 82, 545-562. <https://doi.org/10.1111/j.1540-4781.1998.tb05543.x>
- Makiabadi, H., Pishghadam, R., Naji Meidani, E., & Khajavy, G. H. (2019). Examining the role of emotioncy in willingness to communicate: A structural equation modeling approach. *Revista de Psicodidáctica*, 24(2), 120-130.
- Matthews, M. (1992). Constructivism and empiricism: An incomplete divorce. *Research in Science Education*, 22(1), 299-307.
- McCroskey, J. C. (1997). Willingness to communicate, communication apprehension, and self-perceived communication competence: Conceptualizations and perspectives. In J. A. Daly et al. (Eds.), *Avoiding communication: Shyness, reticence, & communication apprehension* (pp. 75-108). Cresskill, NJ: Hampton Press.
- McCroskey, J. C., & Richmond, V. P. (1990). Willingness to communicate: Differing cultural perspectives. *Southern Journal of Communication*, 56, 72-77.
- McCroskey, J. C., & V. P. Richmond (1996). Willingness to communicate: A cognitive view. In M. Booth- Butterfield (Ed.). *Communication, cognition, and anxiety* (pp. 19-37). Newbury Park, CA: Sage.
- Myréen, S. (2015). Evaluating the role of multisensory elements in foreign language acquisition. *International Journal of Educational and Pedagogical Sciences*, 11(2), 418-421.
- Neumann, H. (2010). *What's in a grade? A mixed methods investigation of teacher assessment of grammatical ability in L2 academic writing*. Unpublished doctoral dissertation, McGill University, Montreal.
- Pishghadam, R. (2015). *Emotioncy in language education: From exvolvement to involvement*. Paper presented at the 2nd Conference of Interdisciplinary Approaches to Language Teaching, Literature, and Translation Studies, Mashhad, Iran.
- Pishghadam, R. (2016a). *Emotioncy, extroversion, and anxiety in willingness to communicate in English*. Paper presented at the 5th International Conference on Language, Education, and Innovation, London, England.
- Pishghadam, R. (2016b). *Introducing emotioncy tension as a potential source of identity crisis*. Paper presented at the 16th Interdisciplinary Conference on Cultural Identity and Philosophy of the Self, London, England.
- Pishghadam, R., & Abbasnejad, H. (2016). Emotioncy: A potential measure of readability. *International Electronic Journal of Elementary Education*, 9(1), 109-123.

- Pishghadam, R., & Abbasnejad, H. (2017). Introducing emotioncy as an invisible force controlling causal decisions: A case of attribution theory. *Polish Psychological Bulletin*, 48(1), 129-140.
- Pishghadam, R., Adamson, B., & Shayesteh, S. (2013). Emotion-based language instruction (EBLI) as a new perspective in bilingual education. *Multilingual Education*, 3(9), 1-16.
- Pishghadam, R., Jajarmi, H., & Shayesteh, S. (2016). Conceptualizing sensory relativism in light of emotioncy: A movement beyond linguistic relativism. *International Journal of Society, Culture & Language*, 4(2), 11-21.
- Pishghadam, R., Seyednozadi, Z., & Zabetipour, M., (2017) Examining teacher credibility and language achievement in light of emotionalization and life syllabus. *International Journal of Pedagogies & Learning*, 12(2), 117-131.
- Pishghadam, R., & Shayesteh, S. (2016). Emotioncy: A postlinguistic approach toward vocabulary learning and retention. *Sri Lanka Journal of Social Sciences*, 39(1), 27-36.
- Pishghadam, R. & Shayesteh, S. (2017a). Emosensory expression at the crossroads of emotion, sense, and language: A case of color-emotion associations. *International Journal of Society, culture, & Language (IJSCL)*, 5(2), 15-25.
- Pishghadam, R., & Shayesteh, S. (2017b). The consolidation of life issues and language teaching on the life-language model of emotioncy. *Humanizing Language Teaching*, 19(1), 1-14.
- Pishghadam, R., Tabatabaeyan, M. S., & Navari, S. (2013). *A critical and practical analysis of first language acquisition theories: The origin and development*. Ferdowsi University of Mashhad Publications.
- Rees, C., Sheard, C., & Davies, S. (2002), The development of a scale to measure medical students' attitudes toward communication skills learning: The communication skills attitude scale (CSAS). *Medical Education*, 36, 141-147. <https://doi.org/10.1046/j.1365-2923.2002.01072.xz>
- Riasati, M. J., & Noordin, N., (2011). Antecedents of willingness to communicate: A review of literature. *Studies in Literature and Language*, 3(2), 74-80. <https://doi.org/10.3968/j.sll.192315632011030226>
- Richards, J. C., & Schmidt, R. (2010). *Dictionary of language teaching and applied linguistics* (4th ed.). Edinburgh: Pearson.
- Scollon, R., & Scollon, S. W. (1995). *Intercultural communication: A discourse approach*. Oxford: Basil Blackwell.
- Susanto, J. (2012). Communicative competence in teaching speaking. *Journal of English and Arabic Language Teaching*, 3(1), 69-86.
- Sweller, J. (1988). Cognitive load during problem solving: Effects on learning. *Cognitive Science*, 12(2), 257-285.
- Syahputri, D. (2019). The effect of multisensory teaching method on the students' reading achievement. *Budapest International Research and Critics in Linguistics and Education (BirLE) Journal*, 2, 124-131. <https://doi.org/10.33258/birle.v2i1.192>
- Thornton, C., Jones, G., & Toohey, M. (1983). A multisensory approach to thinking strategies for remedial instruction in basic addition facts. *Journal for Research in Mathematics Education*, 14(3), 198-203.
- Yashima, T., Zenuk-Nishide, L., & Shimizu, K. (2004). The influence of attitudes and affect on willingness to communicate and second language communication. *Language Learning*, 54(1), 119-152. <https://doi.org/10.1111/j.1467-9922.2004.00250.x>

Appendix
ESC Questionnaire (Three Sample Questions)

Name:	Age:	Gender:	Education:
IELTS Speaking Score:	E-mail:	Cellphone:	

Dear participant:

This questionnaire includes 18 situations that show your way of communicating in them. Please read each situation carefully and choose an option regardless of whether the language is formal or informal.

(Cognitive)

Imagine you want to learn Hindi and you want to ask your friends for their opinion about it. Which question will you probably start your conversation with?

1. Do you know anything about Hindi?
1. Have you ever heard of Hindi?
2. Have you ever watched any Hindi learning video clips?
3. Do you know anyone who knows Hindi?
4. Have you ever participated in Hindi classes?
5. Do you know the best way of learning Hindi?

(Socioemotional)

Imagine you are talking to your boss in his office and you know that there is an election coming up next month. You want to talk about it with your boss. Which question will you probably start your conversation with?

1. Do you know anything about the upcoming election?
2. Have you heard anything about the upcoming election?
3. Have you seen the election posters and speeches of the candidates?
4. Do any of your friends or acquaintances participate in the election?
5. Have you ever participated in elections?
6. Have you researched about the election/candidates?

(Sensory)

Imagine that you are talking to your niece/nephew at home and you want to talk about Game of Thrones series. Which question will you probably start your conversation with?

1. Do you know anything about Game of Thrones?
2. Have you heard anything about Game of Thrones?
3. Have you seen the ads of Game of Thrones anywhere?
4. Is any of your friends or acquaintances following Game of Thrones?
5. Are you following Game of Thrones?
6. Have you searched about the scriptwriter or actors of Game of Thrones?



© 2021 by the authors. Licensee Shahid Chamran University of Ahvaz, Iran. This article is an open access article distributed under the terms and conditions of the Creative Commons Attribution–NonCommercial 4.0 International (CC BY-NC 4.0 license). (<http://creativecommons.org/licenses/by-nc/4.0/>).

